

CWM MODULAR CONTAINER IRRIGATION SYSTEMS Installation, Assembly & Operation

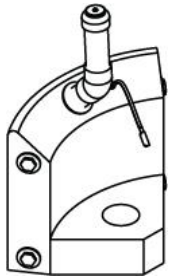

Curved Back and Square Back Systems



CWM – Solo Module
Curved Back

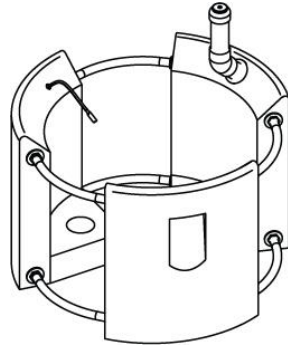

CWM – 3 Module
Curved Back



CWM-R – Solo Module
Square Back

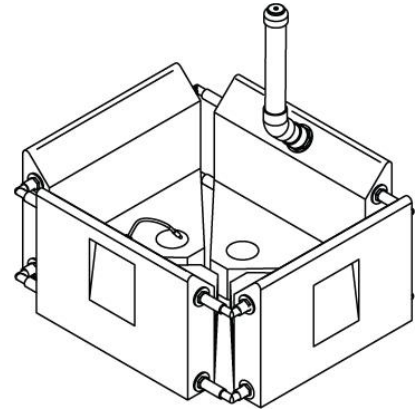

CWM-R – 4 Module
Square Back

This installation, assembly and operation manual covers solo and multi-module systems.

Table of Contents

CWM Systems Contents.....	2
How CWM Modular Irrigation Works.....	5
Preparation.....	6
Assembly.....	9
Planting.....	13
Maintenance.....	17
Warranty.....	20

You can find information about caring for Tournesol products and materials by visiting: <https://tournesol.com/care> where you can download Care & Maintenance documents.

Video Guide

Watch the CWM Container Irrigation Assembly on [YouTube](#).



CWM System Contents

Check system contents prior to beginning assembly. Frequently, BioGuard and silicone caulk are packaged separately – check all boxes before starting.

CWM-XXYY-2k, 3k, 4k, 5k Systems

XX = Module width in inches, YY = Module height in inches



Fill Module
(1 per system)

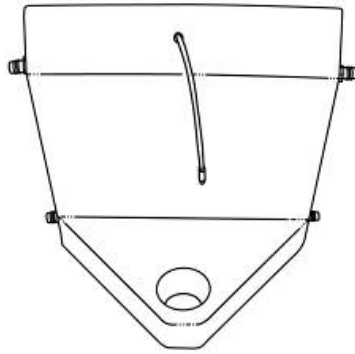

Sensor Module
(1 per system)

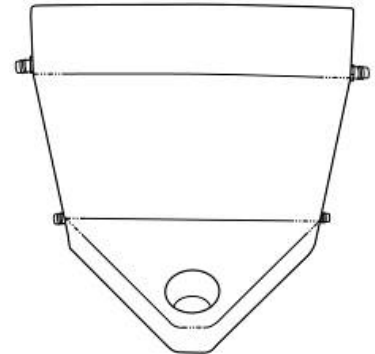

Secondary Module
(2k = 0, 3k = 1, 4k = 2)



Hose Clamp



Tamper-resistant stopper
and 5/32" hex wrench
(usually with fill tube)

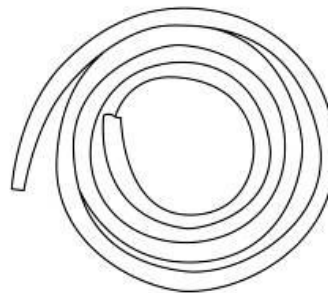

3/4" Braided PVC Tubing

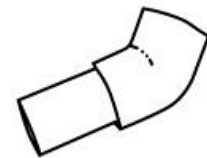

Fill Elbow

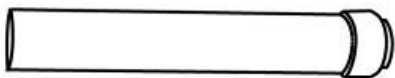

Fill Tube

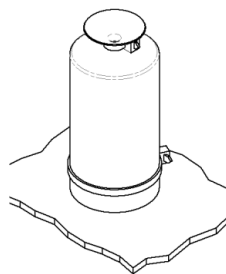

Overflow Drainage
Adapter

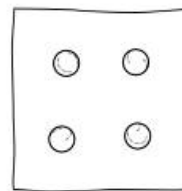

BioGuard Square



Elbows – (square
CRT and ADJ
configurations only)

CWM System Contents



CRT Configuration

For round, square, or wide rectangular containers, all units have hose barbs on both sides. Square-back systems have elbows included.

LIN Configuration

For rectangular containers, two units have plugs on one side, hose barbs on the other, all others have hose barbs.



ADJ Configuration

For smaller square containers, both units have plugs on one side, hose barbs on the other. Includes elbows.

CWM-XXYY-MS (Solo Module Systems)

XX = Module width in inches, YY = Module height in inches

Solo modules are designed to be used on their own. They have plugs on either side, and have both a sensor tube and fill port.

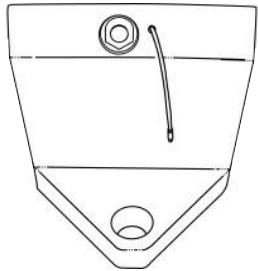

Solo Module
(square-back style shown)



Tamper-resistant stopper
and 5/32" hex wrench
(usually with fill tube)

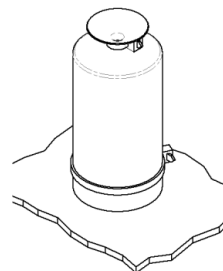

Overflow Drainage
Adapter

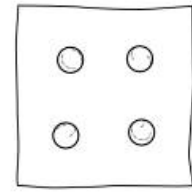

BioGuard Square

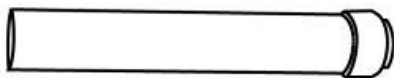

Fill Tube

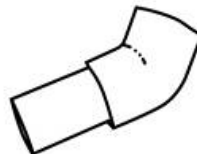

Fill Elbow

CWM System Contents

CWM-XXYY-5kE or CWM-E2400

XX = Module width in inches, YY= Module height in inches

CWM modules are typically installed along the perimeter of planters wider than 60° sometimes need extension modules (part number CWM-E2400) to get water to the center of the pot or planter. A module with a front adapter must be ordered to accommodate the extension tubing included with the extension module.

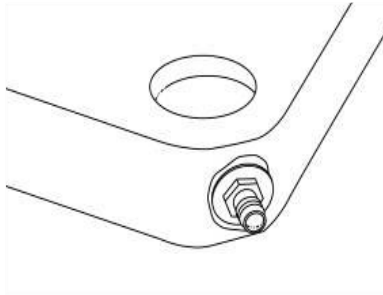

Front Adapter on CWM Module

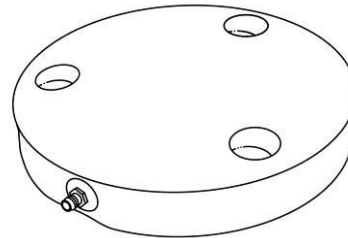

Extension Module (CWM-E2400)



Hose Clamp

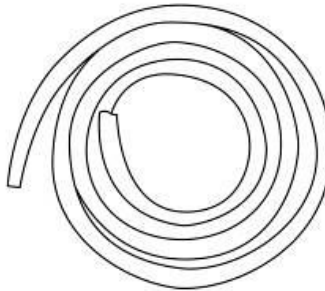

Extension Tubing

How the CWM Modular Container Irrigation System Works

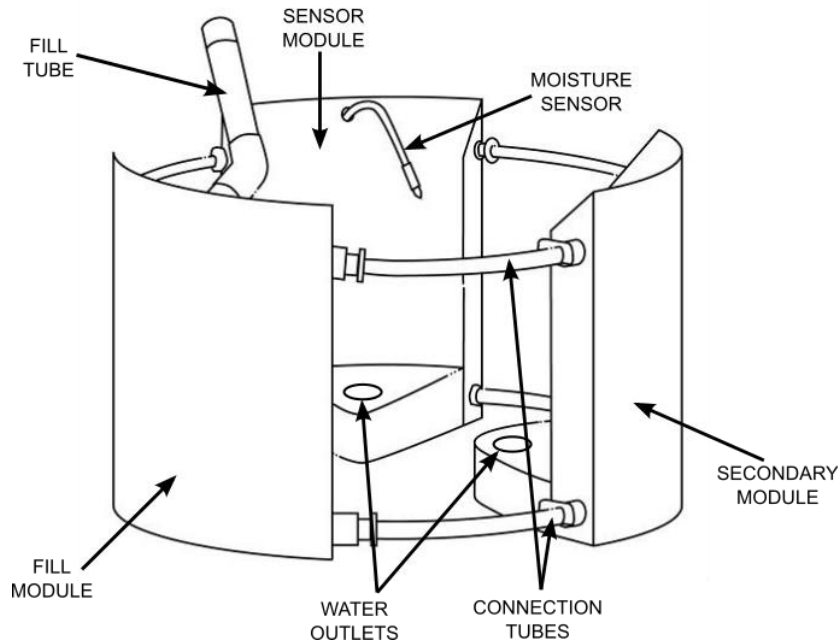

CWMs are modular, self-contained watering systems placed inside a planter before plants and media and are made of reservoirs linked with flexible tubing. CWM systems can be configured using 1 or up to 5 modules depending on the planter size and watering needs.

The modules are filled through a fill tube with a tamper-resistant stopper. When filled with water, air-tight reservoir modules develop a vacuum above the water level. Water in the reservoirs flows through tiny holes in the water outlet on the bottom of each module.

Water flow is controlled by the connected proprietary moisture sensor with a microporous tip that detects moisture levels in the soil. The sensor works as a simple valve, closing and creating a vacuum when moisture levels are sufficient and opening when the soil is dry, breaking the vacuum and releasing water through the water outlets.

Water wicks up through the media until it reaches our proprietary moisture sensor, forming a watering cycle that is only interrupted when refilling the reservoir modules.

The system includes a drainage overflow adapter at the bottom of the planter that allows excess water, typically from stormwater and irrigation water pulled down by gravity, to escape with disrupting the system.

PREPARATION

What You'll Need

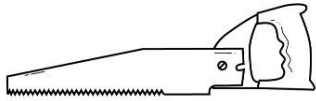

Hacksaw or PVC Shear



PVC Glue

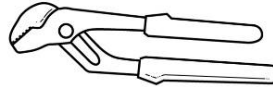

Pliers

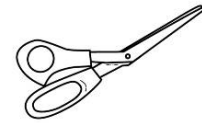

Scissors or Utility Knife

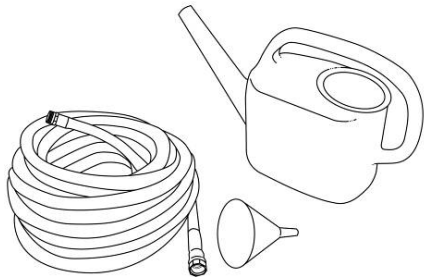

Hose, or Watering Can and Funnel

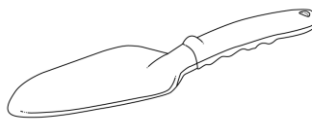

Trowel or Shovel



Potting Media

We recommend using a high-quality potting media, typically a blend of approximately 1/3 peat, 1/3 composted organics, and 1/3 sand, expanded slate, or shale. The mix needs good capillary action for drainage but enough structure so it doesn't compact. *Do not use field soil with any pot or container planting!*

Installation, Drainage Height

The CWM Modular System works best when there is a 6" -12" distance between the top of the module projected bottom and the bottom of the main planting's rootball.

Determine the proper height of the Overflow Drainage Adapter by setting the adapter at the bottom of the planter. Overflow drainage works best when located several inches above the water source (top of water outlets). If it is too short, extend the adapter by gluing a 1-1/2" ABS pipe with a union fitting to extend its height. If too long, cut the adapter down to size. Remove the landscape fabric covering the drain cap before making any adjustments and put it back in place. (See the Overflow Drainage Adapter Installation Instructions included in your shipment for more details.)

Modules can be set directly on the bottom of the planter or staged up with potting media, gravel, or other filling material. If staged up using gravel, do not use the overflow adapter.

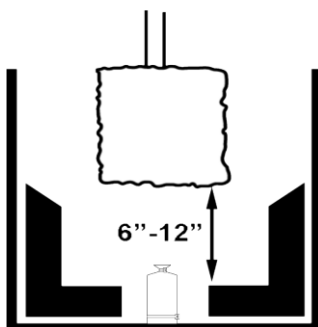

Staging the CWM for deeper tree & underplantings.

Installing the Drainage Adapter

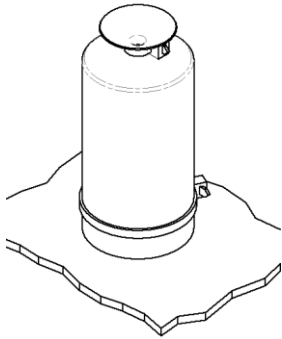

Overflow Drainage Adapter

An Overflow Drainage Adapter should only be used in watertight and sealed planters. Test the adhesive included with your system to ensure it is compatible with your planter’s weatherproofing. The adapter comes in three parts: plug, adapter pipe and drain cap.

Place a small amount of sealant on the lip at the base of the plug, tilt planter to expose the bottom, and place the plug inside of the predrilled drain hole from the outside in. Holding the plug in place, add a small amount of sealant around the drain hole inside the planter and place the adapter pipe directly over the drain hole and plug. Press firmly to set. Apply a bead of sealant between the pipe and the planter. Repeat for all drain holes and return planter right side up.

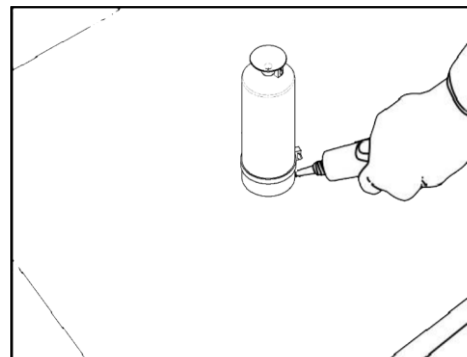
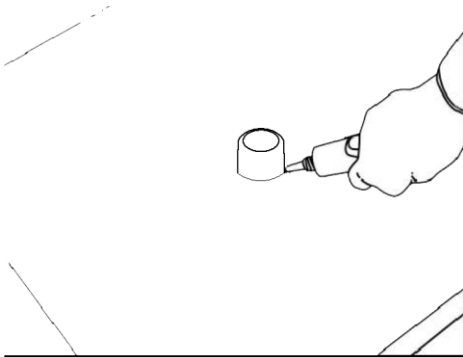

Place drainage cap on the adapter pipe, then cover and secure the cap with the supplied landscape fabric. Securing the fabric with the zip ties included. Set aside for approximately 30 minutes, or until completely dry. This ensures a tight seal. For more detailed instructions see 48-00256-00A (Overflow Drainage Adapter Installation).

Backfill Planter

Using potting media or gravel, backfill the container to level where CWM modules will sit. The top of the Overflow Drainage Adapter should be at least 1” above the level of the gravel. Install soil separator fabric on top of the drainage level, if needed.



CWM MODULAR CONTAINER IRRIGATION SYSTEMS

Installation, Assembly & Operation



Layout Units, Measure & Cut Tubing

Set units into container to confirm fit and layout. No more than 5 units should be linked. Modules should be level, and of the same height. If possible, sensor module should be separated from fill module by a secondary module. Space modules evenly.

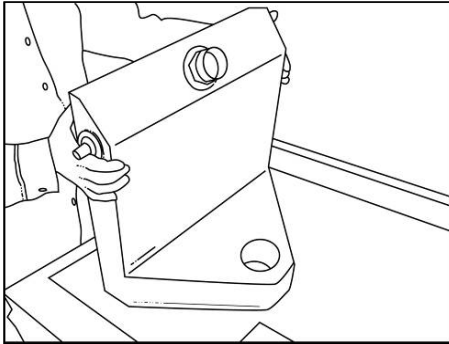

Measure distance between shoulder of hose barbs for tubing. Cut tubing using scissors or utility knife. For curve-back modules, cut slightly longer for hose to curve between modules. For square-back modules in CRT configuration, cut tubing for elbow joints.

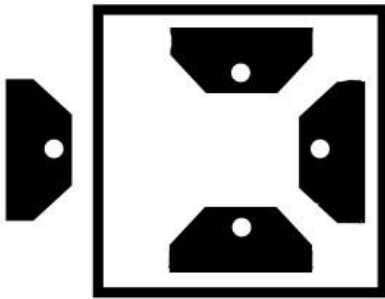

If the system uses an extension module (see p.12), identify which module has the extension adapter, and lay out how it will connect to the extension module. Measure and cut the connecting tube for the extension at this time as well.

ASSEMBLING THE SYSTEM

Attach Modules & Tubing

It is usually easier to remove the modules and assemble the system outside of the pot or planter.

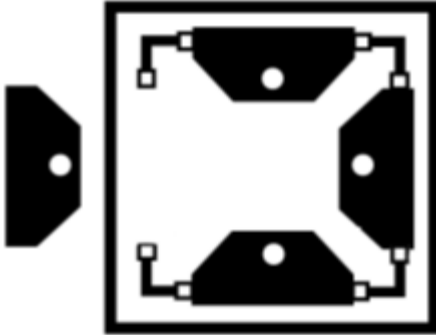

Linear (LIN) and Adjacent (ADJ) configurations may often be assembled completely outside of the container, and slipped inside after assembly. Circuit (CRT) systems can be partially assembled as shown.

Slide the cut lengths of tubing over the hose barsbs, pushing straight on. The tubing will slide over the barb easier if a dab of liquid soap is put on the barb or the tube is softened with hot water.

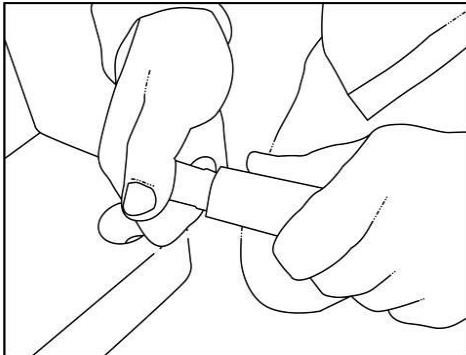

Wrap a hose clamp around each barb. If the clamp needs to be removed, push one end back while pulling the other forward.

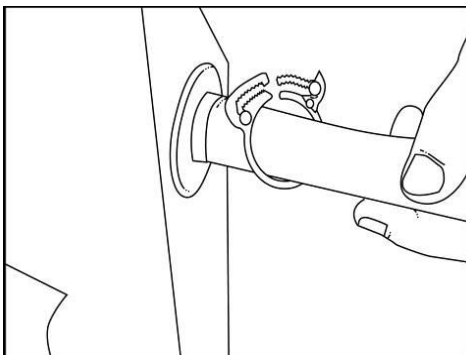

CWM MODULAR CONTAINER IRRIGATION SYSTEMS

Installation, Assembly & Operation



Use a set of pliers to snap clamps closed - a good seal is critical to ensure an air-tight connection, and the unit's function.

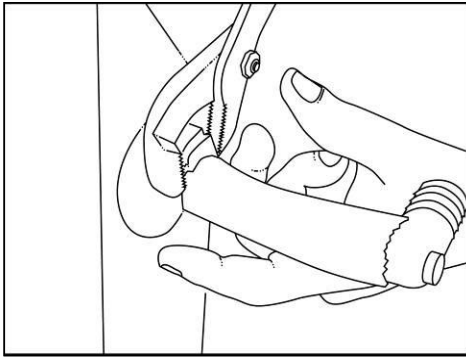

If the system uses an extension module (see p.12), install the connecting tube on the module with the extension adapter prior to placing the partially assembled unit back into the planter. It will make installation of the extension module easier. Make sure the extension module is level with the other modules, and the connecting tube running from the extension adapter to the extension module shouldn't rise or dip.

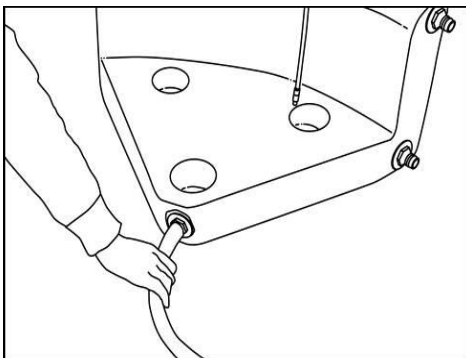

Set partially assembled unit back into container, and connect the final unit.

Assembling the Fill Tube

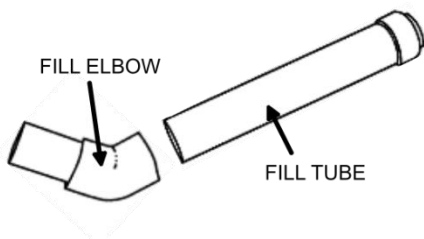

Before cutting or gluing, dry fit the fill tube to the fill elbow. Insert the fill elbow side into the fill module adapter at a 45° angle, then turn vertical. This angle allows for easier and faster filling.

CWM MODULAR CONTAINER IRRIGATION SYSTEMS Installation, Assembly & Operation

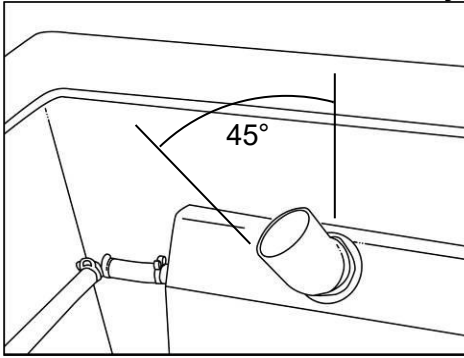

The top of the fill tube should extend 1"-3" over the top of the potting media level. Determine the correct length of the fill elbow and fill pipe. Remove from fill module, and cut to length with hacksaw or PVC cutter.

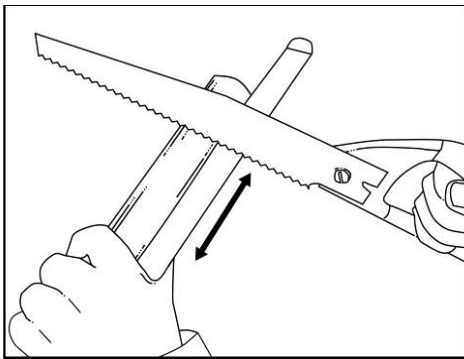

Glue the fill elbow into the module adapter using PVC cement, inserting at a 45° angle, turning until vertical. Next glue the fill tube into the fill elbow.

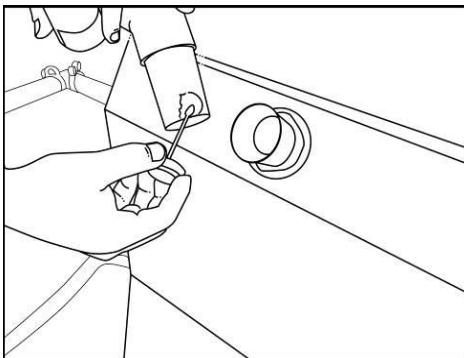

Take this time to make sure that the fill tube's Tamper Resistant Stopper is in place at the top of the fill tube.

CWM MODULAR CONTAINER IRRIGATION SYSTEMS

Installation, Assembly & Operation

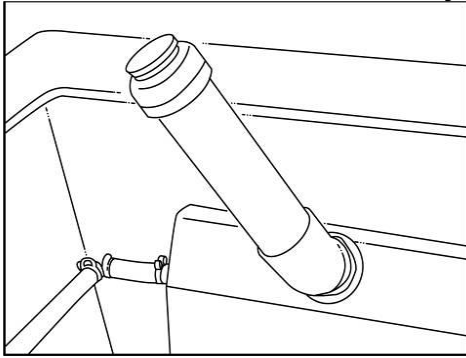

Installing Extension Modules (where applicable)

CWM Modules installed along the perimeter of planters wider than 60" may not provide enough water for the central plantings. By adding one or more extension modules (part. no. CWM-E2400), water can be delivered to larger areas. Typically a CWM system with extension module will have one (or more) modules with an extension adapter pre-installed. This should have already been noted, and the connection tubing installed (see page 4).

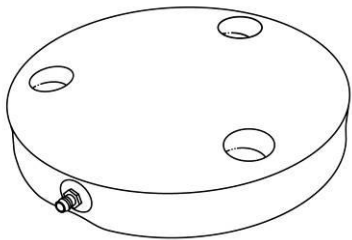

CWM-E2400 Extension Module

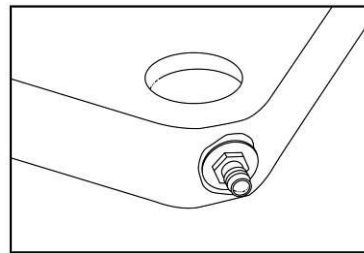

Typical Module with Extension Adapter

The extension module must be level with the other modules, and the connecting tube shouldn't rise or dip as it runs from the extension adapter to the extension module.

Connect the module, pushing the hose straight over the hose barb.

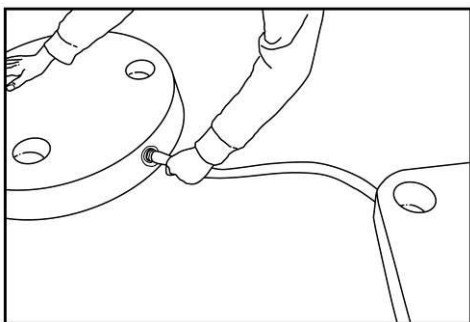

As before, attach hose clamps to both the extension module and the extension adapter, and make sure they are closed tightly with a set of pliers.

PLANTING

Place BioGuard Squares, Backfill with Potting Media

Locate the separately packaged BioGuard squares kit. BioGuard squares are coated with Trifluralin, designed to prevent plant roots from growing into the reservoirs.

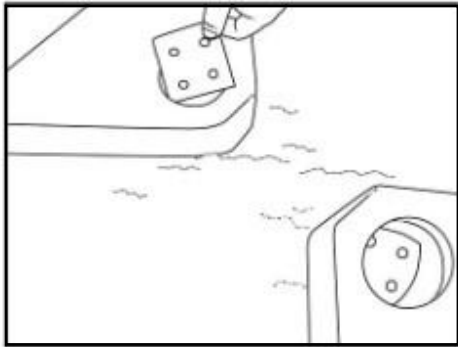

With gloved hands, insert a BioGuard square in the water outlets on each module. It doesn't matter which side goes up. The coating on the squares may cause yellow staining, so handle with care.

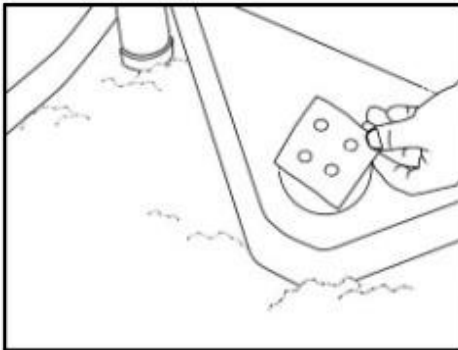

Backfill with potting media, up to the level where the main plant will sit. Pack the potting media firmly into the cups, and around the CWM Modules. The system functions best when the potting media is well packed.

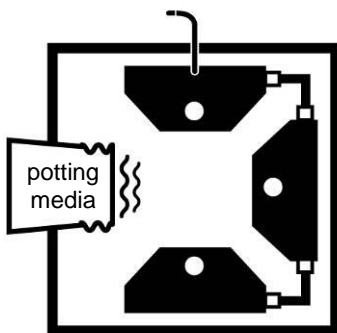

CWM MODULAR CONTAINER IRRIGATION SYSTEMS Installation, Assembly & Operation



Set Primary Plant, Orient as Necessary

Remove the primary plant from its nursery container and place it into the pot or planter.

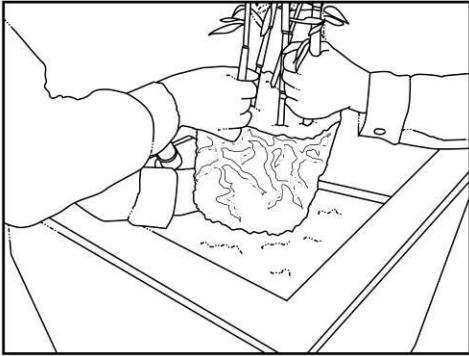

Make sure to orient the main planting properly before continuing to backfill.

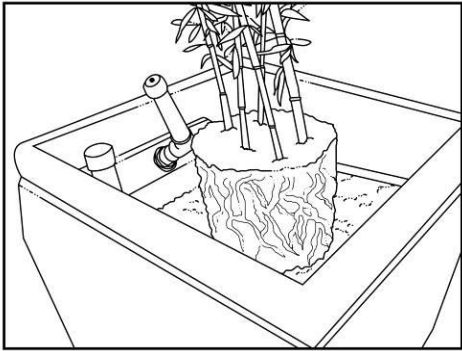

Determine Sensor Height & Location

The moisture sensor is the clear plastic tube with the white tip at the end. The white tip is a microporous plastic that acts as a simple valve.

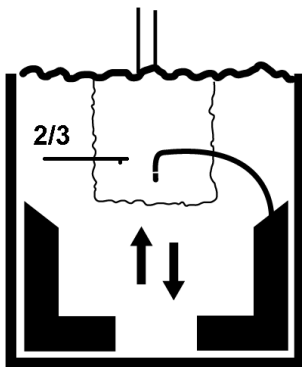

< Adjust the moisture level in the container by raising or lowering the height of the sensor.

By adjusting the height of the sensor up and down, you can control how much water is released from the CWM Modular System. ***The lower the sensor, the drier the soil. The higher the sensor the wetter the soil.***

CWM MODULAR CONTAINER IRRIGATION SYSTEMS Installation, Assembly & Operation

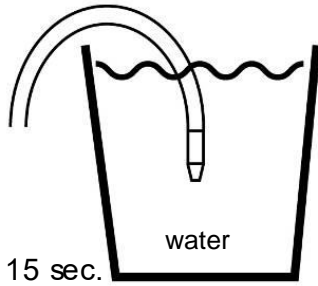

Soaking the tip will form the vacuum required to function optimally and is necessary before inserting it into the potting media and filling the reservoirs with water.

The sensor should be placed approximately 2/3 down the major rootball. The exact orientation of the sensor is not crucial, but it should be packed well into the potting media.

Installing the Moisture Sensor

Backfill the planter with potting media up to the level where the sensor will be placed (typically 2/3 down the major rootball).

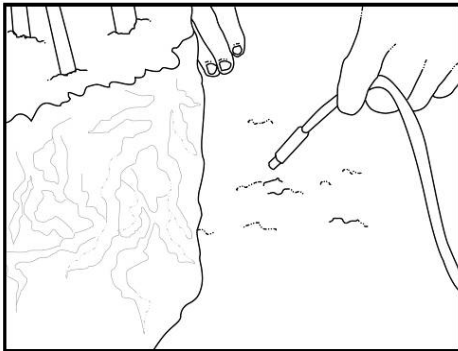

Dig out a small area near the rootball for the sensor, and insert it into the potting media. Back fill with potting media, making sure that the white tip of the sensor has good contact with the surrounding potting media.

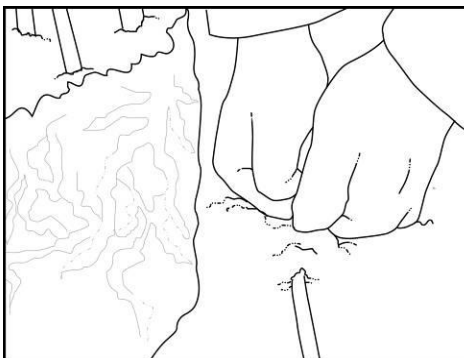

Pack the area around the sensor firmly as you continue to add potting media.

Backfill Soil Around Primary Plant

Backfill potting media up to the desired planting level. The top of the root ball should not be below the potting media level.

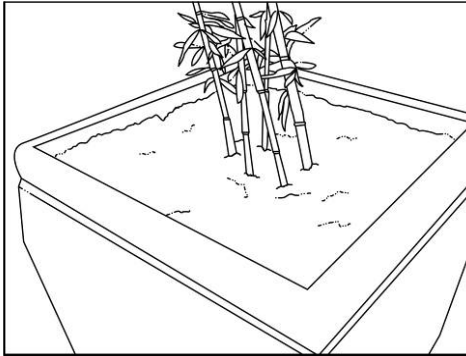

Pack the potting media firmly throughout. If you can easily stick your fingers into the potting media past the second knuckle, keep packing.

Place Underplantings, Pack Potting Media

For best results, start with good size underplantings (1 gal. or 4" jumbo packs). Dig area out for underplantings, place plants and repack potting media.

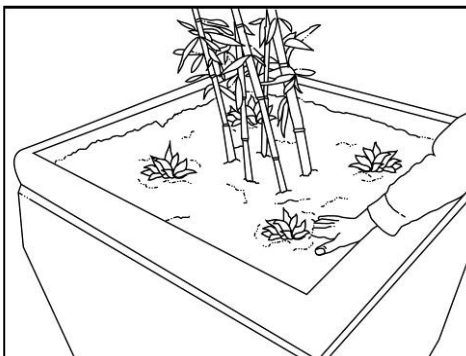

Water the plantings with a medium amount of water to aid settling.

It may take the underplantings some time before their roots reach down to the moisture zone. They may need to be top watered lightly for the first few weeks of maintenance.

MAINTENANCE

Filling the Reservoir

CWM systems have a tamper-resistant stopper that helps maintain the vacuum, which is critical to the system's functionality. The stopper must be reinserted and resealed after every fill. The first system fill will take some time as the reservoirs have a substantial water capacity.

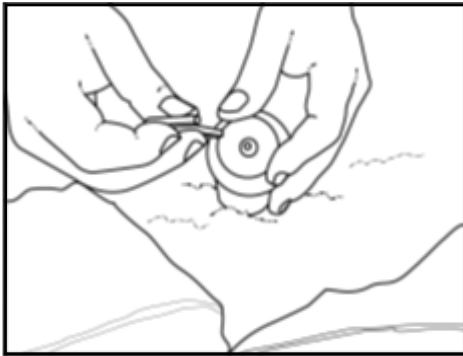

To fill the modules, use the supplied hex wrench to open the tamper-resistant stopper. Turn the hex bolt on the stopper counterclockwise 3 turns and remove the stopper from the fill tube.

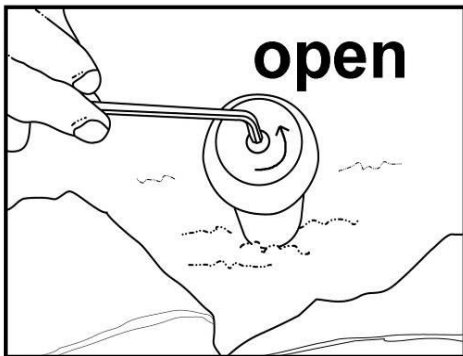

Stick the head of a water hose deep into the fill tube for best results. Begin filling with water and have a shutoff nearby to avoid messy overspill.

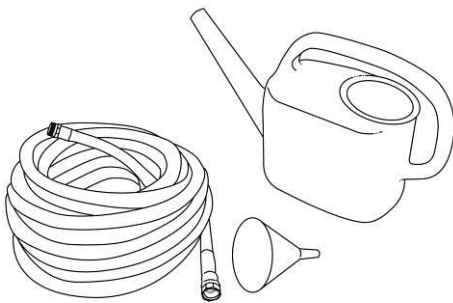

CWM MODULAR CONTAINER IRRIGATION SYSTEMS

Installation, Assembly & Operation

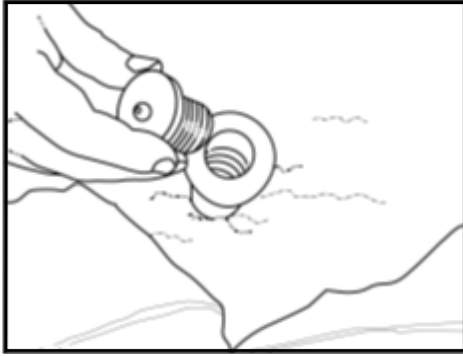

Fill at a medium rate, to allow the water to transfer between modules.

As you fill, remember that the largest systems may have a substantial water capacity and may take some time to fill.

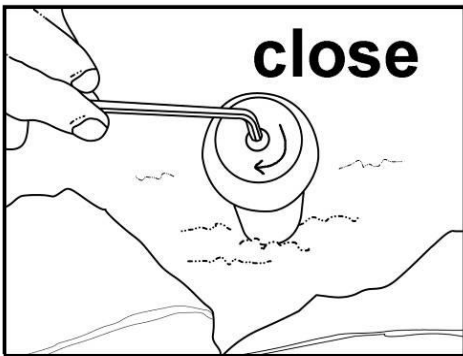

When finished filling, insert the tamper resistant stopper into the fill tube, and tighten the hex bolt 3 turns clockwise. The tube should not be filled more frequently than necessary.

Maintaining the CWM Modular System

Refilling the modules should be a regular part of plant maintenance. In the initial establishment period, monitor the moisture levels in the potting media often. If the media appears dry, increase the filling frequency. If it is too wet (or if excess water leaks from the bott of container), decrease the filling frequency. Watch the relative health of the main plant for signs of stress. Top water the underplantings until their roots reach the moisture zone, typically 1-3 weeks. After a few weeks, the plant's water needs and soil moisture levels should stabilize, and a regular refill schedule should be established. Remember that watering needs may change with seasons or the weather, affecting refill intervals.

Troubleshooting

For overwatering, damp potting media, or excessive drainage, ensure the moisture sensor is planted firmly in the potting media, attached securely to the sensor module, and buried deep in the potting media. Fill less frequently and check that the fill tube stopper is closed tightly after each fill to maintain vacuum.

For underwatering and dry potting media, raise the sensor higher in the potting media for longer watering periods and fill the modules more frequently. In the case of underplantings, top water longer to establish roots.

CWM MODULAR CONTAINER IRRIGATION SYSTEMS

Installation, Assembly & Operation



Winterizing the CWM Modular System

The surrounding potting media insulates the CWM system, requiring relatively little winterization. Ideally, the system will be empty by the first hard frost.

As fall approaches, decrease the filling frequency and stop filling entirely before the first hard frost. Due to the nature of the materials used in constructing the CWM system, having the reservoirs completely empty is unnecessary.



Tournesol Siteworks Limited Three-Year Warranty

Tournesol Siteworks LLC warrants to the initial purchaser of its products that they will repair or replace product that contains a defect in material or workmanship for a period of three years from the date it is delivered to the initial purchaser.

This limited warranty does not include those parts which fall under standard regular maintenance, including but not limited to parts which are subject to periodic replacement. The warranty does not apply to conditions resulting from misuse, abuse, failure to follow directions for use, unauthorized modifications, neglect, accident or other hazard or the like. ***The remedy under this warranty is limited to repair or replacement, at Tournesol Siteworks' option, of the defective parts of the warranted product.*** Repair or replacement of a part does not extend the warranty beyond the initial warranty period.

This is the only written warranty applicable to the product. The duration of the implied warranty on the product is limited to the duration of this express warranty. ***In no event shall Tournesol Siteworks be liable for any incidental or consequential damages, including but not limited to damage to any plants which may have been planted in the product.*** Some states do not allow limitations on how long an implied warranty lasts or the exclusion or limitation of incidental or consequential damages, so the above limitations or exclusions may not apply to you. This warranty gives you specific legal rights and you may also have other rights which may vary from state to state.

For service or if you have any questions or problems, please contact:

Tournesol Siteworks LLC

Union City, CA

800.542.2282

www.tournesol.com