



Aloft Façade Planters

The next generation of hanging planters, Aloft is a superior, precision-engineered system. Crafted from durable aluminum, Aloft features concealed mounting, integral drainage, and an easy mounting system. The product has undergone rigorous testing, ensuring exceptional strength and reliability for any project.

Aloft Façade Planters elevate the look and function of multifamily developments, commercial buildings, hotels, restaurants, parking structures, and civic spaces – bringing greenery to new heights.

Aloft Façade Planters

For more than two decades, Tournesol has led the industry in commercial-grade facade-mounted planters, completing hundreds of successful installations across North America. Drawing on that deep experience — and close collaboration with architects and landscape architects — we've reimagined what a façade planter can be.

Designed for installation on building facades and crafted from durable aluminum, Aloft features an integrated drainage system, and an improved and concealed mounting design that simplifies installation. The product has undergone rigorous testing and third-party review, ensuring exceptional strength and reliability for any project.

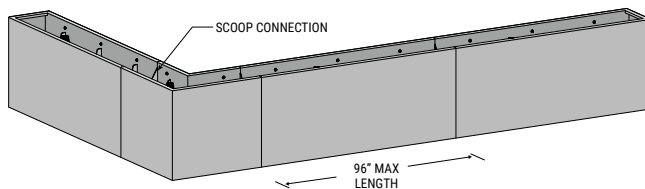

PRODUCT DETAILS

- Aloft includes planter, integral drainage, and mounting system.
- Planters can be connected end-to-end to create linear runs, and can be modified with 'scoops', which lower adjacent planter walls, creating an appearance of a single long planter.
- Select from 26 powder-coat colors or specify a custom color to coordinate with the building's AAMA formulations.

PLANTERS

- Powder-coated 5052-H32 marine-grade aluminum; laser-cut, formed, and welded.
- Internal planter floor sealed with SikaSeal-330 high-temp sealant.
- Welded stiffeners and gussets with mounting cleats.
- Drain cutouts made as required to accommodate drainage.
- Engineered for saturated soil density of 110 lbs per cubic ft.
- Licensed professional engineer calculations and details available.
- Available in 15 sizes across three width x height variations (12" x 24", 15" x 30", 18" x 36").
- Lengths: 48", 60", 72", 96"; multiple units can join to create longer runs.
- Custom planter lengths 48" - 96" may be ordered to fit conditions.
- Standard corner units available.

WE'RE HERE TO HELP

Tournesol's Advisors are here to help you at any point in your project, from planning and quoting to assembly and installation.

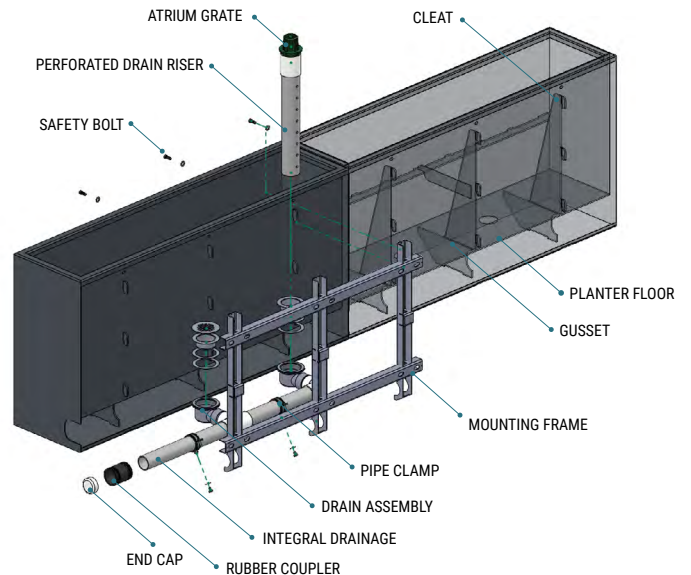

INTEGRAL DRAINAGE

- Sch 40 PVC pipe and drain assembly, factory pre-cut and pre-assembled.
- Drain riser kit includes perforated Sch 40 PVC riser and atrium grate; also supports clean-out.
- Concealed, integral, pre-engineered drainage system that ties into building drain leads.
- Drain inlet/outlet cutouts created in planter walls to accommodate drainage configuration.
- Plumbing bolts directly to the mounting frame.

MOUNTING

Mounting frame constructed from 12-gauge 304 stainless steel; laser-cut, formed, and welded; primer-coated.

1. Install anchors appropriate to the building façade.
2. Bolt mounting frame(s) to the wall for the full planter run.
3. Secure drainage plumbing to the frame; connect additional planters with rubber pipe couplers.
4. Tie drainage into the building as required.
5. Lift planter above final height, lower to engage cleats in the frame, and install safety bolts.
6. Secure drain assembly and risers. Multiple drainage entry/exit location options.

REQUEST A QUOTE

When you are ready to get pricing, submit your plans and project information at tournesol.com/request-quote.

Aloft Façade Planters



PRODUCT	DESCRIPTION	LENGTH	WIDTH	HEIGHT	PLANTING DEPTH	WEIGHT (LBS)	VOLUME (CUBIC FT.)
AFC-301224	Aloft Façade Corner Planter with integral drainage and mounting frame	30" L	12" W	24" H	19" H	74	6
AFR-481224	Aloft Façade Planter with integral drainage and mounting frame	48" L	12" W	24" H	19" H	59	6
AFR-601224	Aloft Façade Planter with integral drainage and mounting frame	60" L	12" W	24" H	19" H	70	8
AFR-721224	Aloft Façade Planter with integral drainage and mounting frame	72" L	12" W	24" H	19" H	85	9
AFR-961224	Aloft Façade Planter with integral drainage and mounting frame	96" L	12" W	24" H	19" H	106	12
AFC-331530	Aloft Façade Corner Planter with integral drainage and mounting frame	33" L	15" W	30" H	25" H	97	11
AFR-481530	Aloft Façade Planter with integral drainage and mounting frame	48" L	15" W	30" H	25" H	81	10
AFR-601530	Aloft Façade Planter with integral drainage and mounting frame	60" L	15" W	30" H	25" H	99	13
AFR-721530	Aloft Façade Planter with integral drainage and mounting frame	72" L	15" W	30" H	25" H	113	15
AFR-961530	Aloft Façade Planter with integral drainage and mounting frame	96" L	15" W	30" H	25" H	177	20
AFC-361836	Aloft Façade Corner Planter with integral drainage and mounting frame	36" L	18" W	36" H	31" H	122	17
AFR-481836	Aloft Façade Planter with integral drainage and mounting frame	48" L	18" W	36" H	31" H	104	15
AFR-601836	Aloft Façade Planter with integral drainage and mounting frame	60" L	18" W	36" H	31" H	156	19
AFR-721836	Aloft Façade Planter with integral drainage and mounting frame	72" L	18" W	36" H	31" H	177	23
AFR-961836	Aloft Façade Planter with integral drainage and mounting frame	96" L	18" W	36" H	31" H	212	31

PART NUMBER	DESCRIPTION	WEIGHT (LBS)
AFR-GSB-BM	Greenscreen Bracket for mounting to bottom of planter - powder-coated	1
AFR-GSB-TM	Greenscreen Bracket for mounting to top of planter - powder-coated	1
AFR-ODT	Aloft Façade Drain Riser Kit, 30" - field cuttable	3

